

INTECH ENGINEERING

MANUFACTURERS OF INDUSTRIAL VALVES

ISO 9001:2008 Certified Company

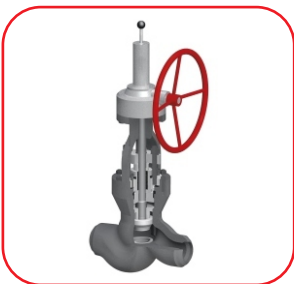
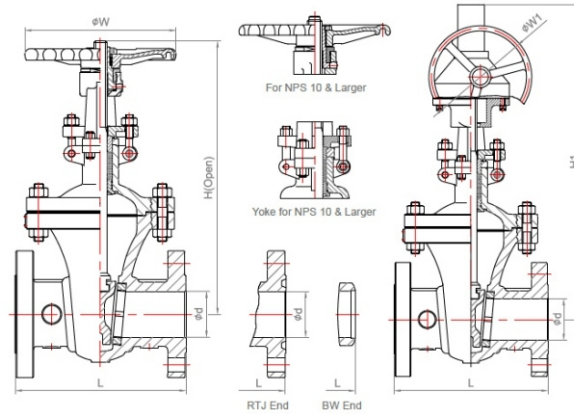

TIFA VALVES™

Email : intechengineering786@gmail.com
tifavalves@gmail.com



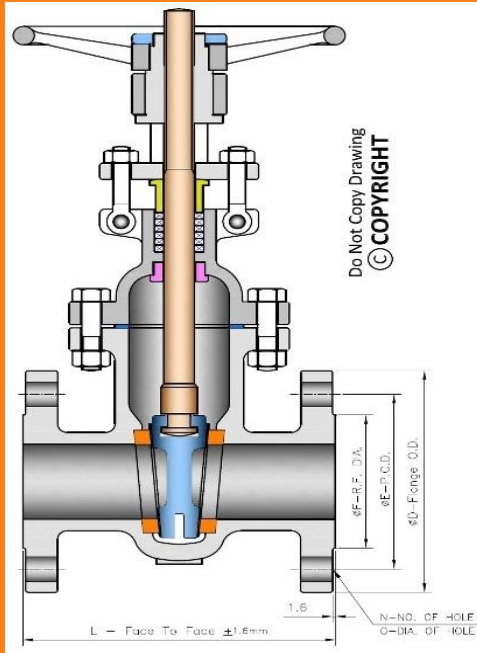

Size	2" (50mm) To 24" (600mm)
Class	150# / 300# / 600# / 900# / 1500#
End	Flanged End To ASME B16.5 RF
	Butt Weld Ends To ASME B16.25
Design / Mfg. STD.	API 600 / API 603 / BS 1414
Face To Face	ASME B16.10
Inspection & Testing STD.	API 598

Gate Valve

*** Special Material & Higher Size/Class Valves Also Available On Requirment**

We Make In all Grade With Complate Chemichal & Mechanichal Property. Grade Are As Below

Grade	ASTM A 216 Gr. WCA / WCB / WCC
NIKLE CARBON MOLYDENIUM	ASTM A 217 Gr. WC1 / WC4 / WC5 / WC6 / WC9 / WC11
CHROMIUM & MOLYDENIUM	ASTM A 217 Gr. C5 / C12 / C12A / CA15
AUSTANATIC STEEL	ASTM A 351 Gr. CF3 / CF8 / CF3M / CF8M / CF8C
LOW CARBON	ASTM A 352 Gr. LCB / LCC
DUCTILE IRON	DUCTILE IRON IS 210 Gr. FG-200
	DUCTILE IRON ISO 1083 Gr. 450-10
	DUCTILE IRON DIN EN 1563 Gr. EN GJS 400-15

Testing Pressure				
Testing	Hydraulic			Pnumatic
Class	150#	300#	600#	-
Body	425 Psi	1100 Psi	2175 Psi	-
Back Seat	300 Psi	800 Psi	1600 Psi	-
Seat	300 Psi	800 Psi	1600 Psi	80 Psi

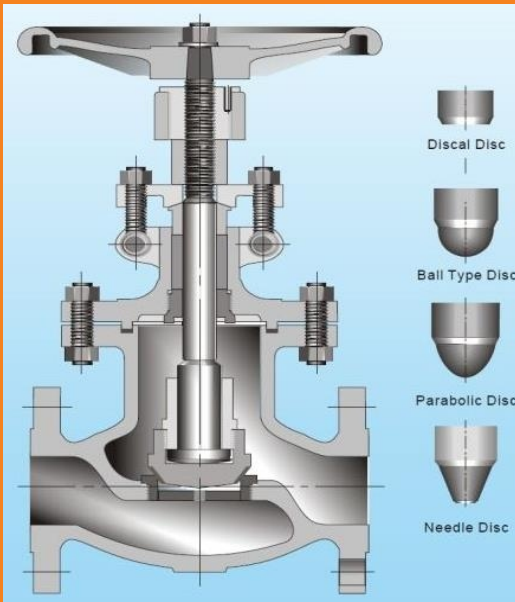

Size	2" (50mm) To 14" (350mm)
Class	150# / 300# / 600# / 900# / 1500#
End	Flanged End To ASME B16.5 RF
	Butt Weld Ends To ASME B16.25
Design / Mfg. STD.	BS 1873
Face To Face	ASME B16.10
Inspection & Testing STD.	API 598 / BSEN 12266 PI

Globe Valve

*** Special Material & Higher Size/Class Valves Also Available On Requirment**

We Make In all Grade With Complate Chemichal & Mechanichal Property. Grade Are As Below

Grade	ASTM A 216 Gr. WCA / WCB / WCC
NIKLE CARBON MOLYDENIUM	ASTM A 217 Gr. WC1 / WC4 / WC5 / WC6 / WC9 / WC11
CHROMIUM & MOLYDENIUM	ASTM A 217 Gr. C5 / C12 / C12A / CA15
AUSTANATIC STEEL	ASTM A 351 Gr. CF3 / CF8 / CF3M / CF8M / CF8C
LOW CARBON	ASTM A 352 Gr. LCB / LCC
DUCTILE IRON	DUCTILE IRON IS 210 Gr. FG-200
	DUCTILE IRON ISO 1083 Gr. 450-10
	DUCTILE IRON DIN EN 1563 Gr. EN GJS 400-15

Testing Pressure				
Testing	Hydraulic			Pnumatic
Class	150#	300#	600#	-
Body	425 Psi	1100 Psi	2175 Psi	-
Back Seat	300 Psi	800 Psi	1600 Psi	-
Seat	300 Psi	800 Psi	1600 Psi	80 Psi

Swing Check Valve

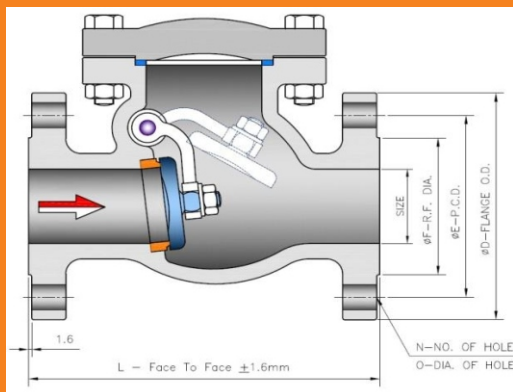

Size	2" (50mm) To 24" (350mm)
Class	150# / 300# / 600# / 900# / 1500#
End	Flanged End To ASME B16.5 RF
	Butt Weld Ends To ASME B16.25
Design / Mfg. STD.	BS 1873
Face To Face	ASME B16.10
Inspection & Testing STD.	API 598 / BSEN 12266 PI

*** Special Material & Higher Size/Class Valves Also Available On Requirment**

We Make In all Grade With Complate Chemichal & Mechanichal Property. Grade Are As Below

Grade	ASTM A 216 Gr. WCA / WCB / WCC
NIKLE CARBON MOLYDENIUM	ASTM A 217 Gr. WC1 / WC4 / WC5 / WC6 / WC9 / WC11
CHROMIUM & MOLYDENIUM	ASTM A 217 Gr. C5 / C12 / C12A / CA15
AUSTANATIC STEEL	ASTM A 351 Gr. CF3 / CF8 / CF3M / CF8M / CF8C
LOW CARBON	ASTM A 352 Gr. LCB / LCC
DUCTILE IRON	DUCTILE IRON IS 210 Gr. FG-200
	DUCTILE IRON ISO 1083 Gr. 450-10
	DUCTILE IRON DIN EN 1563 Gr. EN GJS 400-15

Testing Pressure				
Testing	Hydraulic			Pnumatic
Class	150#	300#	600#	-
Body	425 Psi	1100 Psi	2175 Psi	-
Back Seat	300 Psi	800 Psi	1600 Psi	-
Seat	300 Psi	800 Psi	1600 Psi	-

' Y " Strainer

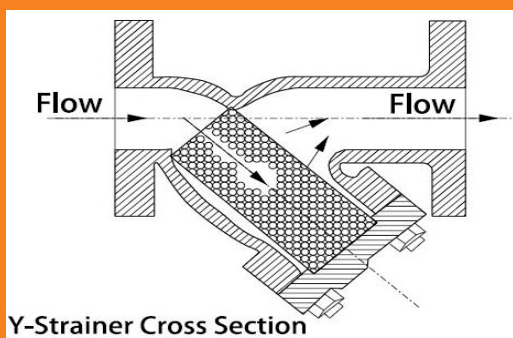

Size	2" (50mm) To 24" (600mm)
Class	150# / 300# / 600# / 900# / 1500#
End	Flanged / Threaded / Socket Weld Ends
	Butt Weld Ends To ASME B16.25
Design / Mfg. STD.	Mfg. Standard
Face To Face	Strainer Screens- Perforated + Wire Mesh
Inspection & Testing STD.	API 598

*** Special Material & Higher Size/Class Valves Also Available On Requirment**

We Make In all Grade With Complate Chemichal & Mechanichal Property. Grade Are As Below

Grade	ASTM A 216 Gr. WCA / WCB / WCC
NIKLE CARBON MOLYDENIUM	ASTM A 217 Gr. WC1 / WC4 / WC5 / WC6 / WC9 / WC11
CHROMIUM & MOLYDENIUM	ASTM A 217 Gr. C5 / C12 / C12A / CA15
AUSTANATIC STEEL	ASTM A 351 Gr. CF3 / CF8 / CF3M / CF8M / CF8C
LOW CARBON	ASTM A 352 Gr. LCB / LCC
DUCTILE IRON	DUCTILE IRON IS 210 Gr. FG-200
	DUCTILE IRON ISO 1083 Gr. 450-10
	DUCTILE IRON DIN EN 1563 Gr. EN GJS 400-15

Testing Pressure				
Testing	Hydraulic			Pnumatic
Class	150#	300#	600#	-
Body	425 Psi	1100 Psi	2175 Psi	-



INTECH ENGINEERING

- : FACTORY 1 :-

Plot No. B9, Archana Industrial Estate -2, Beside Banner Eastate,
Opp. Soma Textile Mile, Rakhial Road, Ahmedabad - 380023. Gujarat (INDIA)

Mo : 9033231668 / 9898312665 / 9173108610

E Mail : intechengineering786@gmail.com

GSTIN : 24DASPS7341D1ZE

- : NEW FACTORY 2 :-

Survey No. 197/1. Plot No.79 AL Asra Estate Behind R.V. Denim Factory,
Narol - Sarkhej Road, Narol, Ahmedabad - 382405. Gujarat (INDIA)

E Mail : tifavalves@gmail.com

Director : S. Abdul Samad

TIFA VALVES™

